



motorola

Quick Start Guide

MODELS: Escape 800 ANC

Product ID: SH043

Bluetooth ID: D036701

FCC ID: VLJ-SH043

IC: 4522A-SH043

Frequency Band: 2.402 – 2.480 GHz

Maximum RF power: 8.5dBm

Working temperature: 0°C – 45°C

1. At a Glance

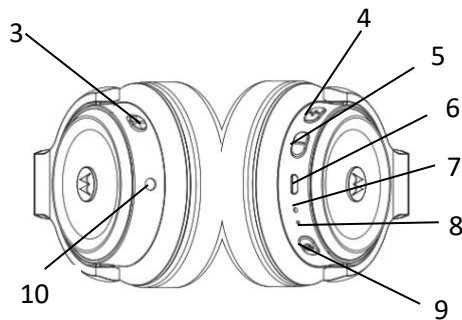
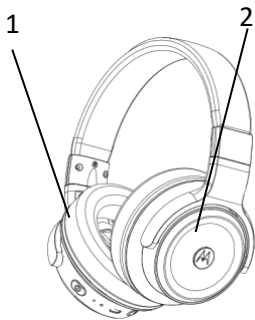

1. Left Ear cup
2. Right Ear cup
3. ANC on / off
4. Volume Up/Next Track
5. Volume Down/Last Track
6. Micro USB Port
7. LED Indicator
8. Microphone
9. Play / Pause / Power
10. AUX-IN

2. Charge

Fully charge before use. Any attempt to remove or replace your battery will damage your headset.

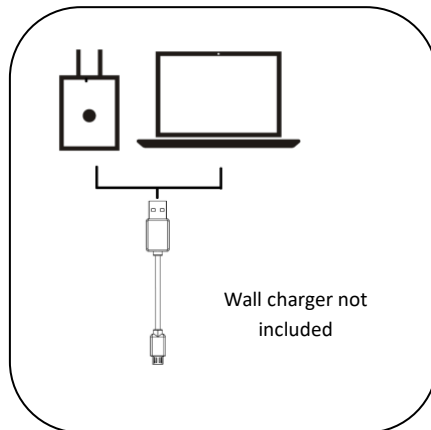

- Charge: Before use, charge until the status light turns blue.
- When battery runs out, charge headphones for 1 second before using with included headphone cable to continue listening.



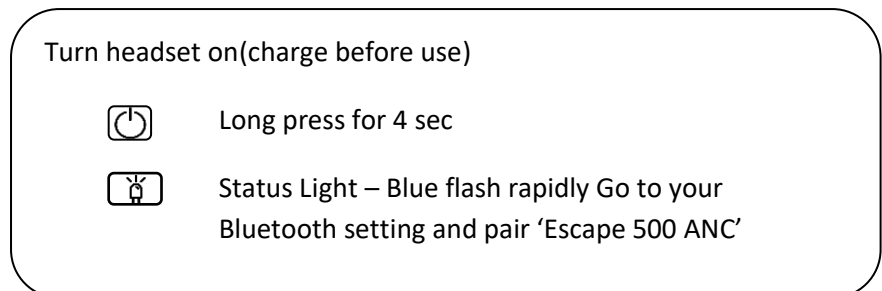
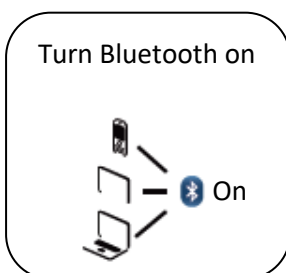



3. Connect & Go



Note: The Battery should only be removed by a recycling facility. Any attempt to remove or replace your battery will damage the product and void your warranty.

Caution: RISK OF EXPLOSION IF BATTERY IS REPLACED BY AN INCORRECT TYPE. DISPOSE OF USED PRODUCT PROPERLY.

4. Buttons Operation

Music	
Play/Pause	Press 
Volume Down/Up	Press - / +
Next Track	Long press + for 2s
Previous Track	Long press - for 2s
ANC on / off	Slide ANC switch button
Calls	
Answer/ end call	Press 
Reject a call/	Long Press - / + for 2s
Call waiting	
Receive incoming call and end ongoing call	Press 
Mute during call	Press - and +
Pair	
Enter pairing mode (first time)	Press and hold  for 4s
Enter pairing mode	Press and hold  for 2s
Voice	
To issue a voice command during idle mode, then say the command	Double Press 

5. LED Indicators

Charging Case (LED at the front)	
Pairing	Blue flash
Standby	LED off
Charging	Red steady
Fully charged	Blue steady
Battery low	Red flash

6. Hubble Connect™ for VerveLife™

Download 'Hubble Connect for VerveLife' app for free at the App Store® or Google Play™ (Android™ 4.4.4 or higher) to find more functions:

- **Last connected location:** Locate in a map where your earbuds were connected to your device last time.
- **Help:** Get help and support.
- **Update for more advanced functions to come**

Note: Application feature may change over time, please download the latest version of the app to see all current features supported.





7. Safety Instructions

To avoid hearing damage, keep the volume at a moderate level. Avoid listening to music at loud volume levels for prolonged periods of time as this may cause permanent hearing damage or hearing loss. Don't use this product when it is unsafe to do so. For example, while operating a vehicle, cycling, crossing a road, or any activity which requires your attention and ability to hear.

7. Help & more

- **Get help:** Visit www.motorolastore.com/support or visit www.verve.life for help videos, FAQ's and more.
- **Find accessories at:** www.motorolastore.com or www.verve.life

Manufactured, distributed, or sold by Binatone Electronics International LTD., official licensee for this product. MOTOROLA and the Stylized M logo are trademarks or registered trademarks of Motorola Trademark Holdings, LLC. and are used under license. Apple logo is a trademark of Apple Inc., registered in the U.S. and other countries. App Store is a service mark of Apple Inc. Google Play and Android are trademarks of Google Inc. All other trademarks are the property of their respective owners. © 2017 Motorola Mobility LLC. All rights reserved.

General information

Safety, Regulatory & Legal

If your product is not working properly, read this Quick Start Guide or the User's Guide of one of the models listed on page 1.

Contact Customer Service:

+44 (0) 844 557 0890 (UK only – Calls cost 7p per minute plus your telephone company's access charge.) +44 (0) 8187 62092 (ROI)

+1-888-331-3383 (US and Canada)

On the Web: www.motorolastore.com/support

Consumer Products and Accessories Limited Warranty ("Warranty")

Thank you for purchasing this Motorola branded product manufactured under license by Binatone Electronics International LTD ("BINATONE").

What Does this Warranty Cover?

Subject to the exclusions contained below, BINATONE warrants that this Motorola branded product ("Product") or certified accessory ("Accessory") sold for use with this product that it manufactured to be free from defects in materials and workmanship under normal consumer usage for the period outlined below. This Warranty is your exclusive warranty and is not transferable. Who is covered?

This Warranty extends only to the first consumer purchaser, and is not transferable.

What will BINATONE do?

BINATONE or its authorized distributor at its option and within a commercially reasonable time, will at no charge repair or replace any Products or Accessories that does not conform to this Warranty. We may use functionally equivalent reconditioned / refurbished / pre-owned or new Products, Accessories or parts.

What Other Limitations Are There?

ANY IMPLIED WARRANTIES, INCLUDING WITHOUT LIMITATION THE IMPLIED WARRANTIES OF MERCHANTABILITY AND FITNESS FOR A PARTICULAR PURPOSE, SHALL BE LIMITED TO THE DURATION OF THIS LIMITED WARRANTY, OTHERWISE THE REPAIR OR REPLACEMENT PROVIDED UNDER THIS EXPRESS LIMITED WARRANTY IS THE EXCLUSIVE REMEDY OF THE CONSUMER, AND IS PROVIDED IN LIEU OF ALL OTHER WARRANTIES, EXPRESS OR IMPLIED. IN NO EVENT

SHALL MOTOROLA OR BINATONE BE LIABLE, WHETHER IN CONTRACT OR TORT (INCLUDING NEGLIGENCE) FOR DAMAGES IN EXCESS OF THE PURCHASE PRICE OF THE PRODUCT OR ACCESSORY, OR FOR ANY INDIRECT, INCIDENTAL, SPECIAL OR CONSEQUENTIAL DAMAGES OF ANY KIND, OR LOSS OF REVENUE OR PROFITS, LOSS OF BUSINESS, LOSS OF INFORMATION OR OTHER FINANCIAL LOSS ARISING OUT OF OR IN CONNECTION WITH THE ABILITY OR INABILITY TO USE THE PRODUCTS OR ACCESSORIES TO THE FULL EXTENT THESE DAMAGES MAY BE DISCLAIMED BY LAW.

Some jurisdictions do not allow the limitation or exclusion of incidental or consequential damages, or limitation on the length of an implied warranty, so the above limitations or exclusions may not apply to you. This Warranty gives you specific legal rights, and you may also have other rights that vary from one jurisdiction to another.

Consumer Products	One (1) year from the date of the products original purchase by the first consumer purchaser of the product
Consumer Accessories	Ninety (90) days from the date of the accessories original purchase by the first consumer purchaser of the product
Consumer Accessories that are Repaired or Replaced	The balance of the original warranty or for Ninety (90) days from the date returned to the consumer, whichever is longer.

commercial purposes or subjecting the Product or Accessory to abnormal usage or conditions; or (d) other acts which are not the fault of MOTOROLA or BINATONE, are excluded from coverage.

Use of Non-Motorola branded Products and Accessories. Defects or damage that result from the use of Non-Motorola branded or certified Products or Accessories or other peripheral equipment are excluded from coverage.

Unauthorized Service or Modification. Defects or damages resulting from service, testing, adjustment, installation, maintenance, alteration, or modification in any way by someone other than MOTOROLA, BINATONE or its authorized service centers, are excluded from coverage.

Altered Products. Products or Accessories with (a) serial numbers or date tags that have been removed, altered or obliterated; (b) broken seals or that show evidence of tampering; (c) mismatched board serial numbers; or (d) nonconforming or non-Motorola branded housings, or parts, are excluded from coverage. Communication Services. Defects, damages, or the failure of Products or Accessories due to any communication service or signal you may subscribe to or use with the Products or Accessories is excluded from coverage. How to Obtain Warranty Service or Other Information? To obtain service or information, please call: +44 (0) 844 557 0890 (UK only – Calls cost 7p per minute plus your telephone company’s access charge.) +44 (0) 8187 62092 (ROI)

US and Canada 1-888-331-3383 On the Web: www.motorolastore.com/support You will receive instructions on how to ship the Products or Accessories at your expense and risk, to a BINATONE Authorized Repair Center. To obtain service, you must include: (a) the Product or Accessory; (b) the original proof of purchase (receipt) which includes the date, place and seller of the Product;(c) if

a warranty card was included in your box, a completed warranty card showing the serial number of the Product; (d) a written description of the problem; and, most importantly; (e) your address and telephone number.



European Union Directives Conformance Statement

The following CE compliance information is applicable to Motorola products that carry one of the following CE marks:

Hereby, Binatone declares that this product is in compliance with:

- The essential requirements and other relevant provisions of RED Directive 2014/53/EU
- All other relevant EU Directives
- The Declaration of Conformity can be obtained at <https://hubbleconnected.com/eu/eu-documents-of-conformity>

FCC Notice to Users

The following statement applies to all products that bear the FCC logo and/or FCC ID on the product label.

This equipment has been tested and found to comply with the limits for a Class B digital device, pursuant to part 15 of the FCC Rules. See 47 CFR Sec. 15.105(b).

These limits are designed to provide reasonable protection against harmful interference in a residential installation. This equipment generates, uses and can radiate radio frequency energy and, if not installed and used in accordance with the instructions, may cause harmful interference to radio communications.

However, there is no guarantee that interference will not occur in a particular installation. If this equipment does cause harmful interference to radio or television reception, which can be determined by turning the equipment off and on, the user is encouraged to try to correct the interference by one or more of the following measures:

- Reorient or relocate the receiving antenna.
- Increase the separation between the equipment and the receiver.
- Connect the equipment to an outlet on a circuit different from that to which the receiver is connected.
- Consult the dealer or an experienced radio/TV technician for help.

This device complies with part 15 of the FCC Rules. Operation is subject to the following two conditions: (1) This device may not cause harmful interference,

and (2) this device must accept any interference received, including interference that may cause

undesired operation. See 47 CFR Sec. 15.19(a)(3). Motorola has not approved any changes or modifications to this device by the user. Any changes or modifications could void the user's authority to operate the equipment. See 47 CFR Sec. 15.21.

Industry Canada Notice to Users

This device complies with Industry Canada license-exempt RSS standard(s). Operation is subject to the following two conditions: (1) This device may not cause interference and (2) This device must accept any interference, including interference that may cause undesired operation of the device. See RSS-Gen, Section 8.4. This device complies with ICES-003 requirements for Class B ITE (Information Technology Equipment). CAN ICES-3 (B)/NMB-3(B)

This device meets the IC requirements.